

## MAGPRO 75/4s Swivel Base

With adjustable magnetic base and 4 speeds

- The magnetic base swivels **15 degrees** left and right and up to **20 mm** forward.
- The adjustable base allows precise positioning for cutting, tapping and drilling.

### Specifications

Power input	1.800 W
Voltage	230V/50Hz
Speed (no load / full load)	1: 210 / 120 rpm
	2: 270 / 160 rpm
	3: 410 / 290 rpm
	4: 530 / 310 rpm
Shank	Weldon 19/32 mm, MT3
Max. Ø core drills x L	12 - 75 x 75 mm
Max. Ø twist drills x L	16 x 110 mm
Max. Ø twist drills x L MT3	32 x 150 mm
Max. depth x Ø	75 x 75 mm
Stroke	100 mm
Magnetic adhesion	32.000 N
Magnetic surface	200 x 100 mm
Cooling system	integrated, automatic
Net weight	27 kg

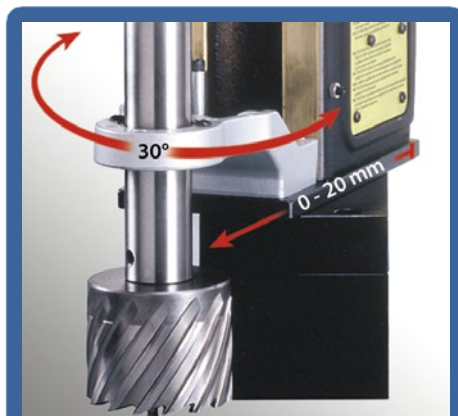

### Description

Description	Ref.
MAGPRO 75/4s Swivel Base - 230V in suitcase with safety chain, maintenance tools and MT3/19 mm adapter	490160S
MT3 Quick change adapter for thread cutter shank M3-M14	490162
Quick change inserts M3-M14 (single)	490162 M3-14
MT3 Quick change adapter for thread cutter shank M5-M22	490165
Quick change inserts M5-M22 (single)	490162 M5-22
Weldon 32/MT3 shank for core drills from Ø 61 mm	490163
Core drill set 30 mm Ø 12, 14, 16, 18, 20, 22 mm with pilot pin	490145
Drill chuck 16 mm and adapter	490164
High Performance Cutting Oil Spray (400 ml)	490020